

P-Channel Enhancement Mode MOSFET

1. Product Information

1.1 Features

- Advanced trench cell design
- Low Thermal Resistance

1.2 Applications

- Motor driver
- DC - DC Converter

1.3 Quick reference

- $BV \cong -60\text{ V}$
- $R_{DS(ON)} \cong 55\text{ m}\Omega @ V_{GS} = -10\text{ V}$
- $P_{tot} \cong 35\text{ W}$
- $R_{DS(ON)} \cong 65\text{ m}\Omega @ V_{GS} = -4.5\text{ V}$
- $I_D \cong -25\text{ A}$

2. Pin Description

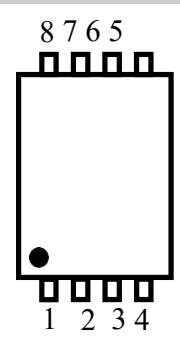
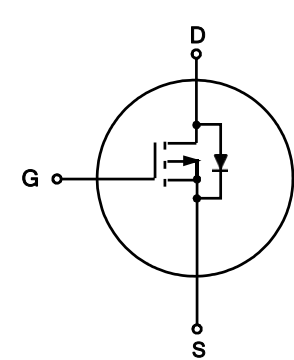
Pin	Description	Simplified Outline	Symbol
1,2,3	Source	 <p style="text-align: center;">Top View PDFN5x6-8L</p>	
4	Gate		
5,6,7,8	Drain		

3. Limiting Values

Symbol	Parameter	Conditions	Min	Max	Unit
V_{DS}	Drain-Source Voltage	$T_C = 25\text{ }^\circ\text{C}$	-	-60	V
V_{GS}	Gate-Source Voltage	$T_C = 25\text{ }^\circ\text{C}$	-	± 20	V
I_D^*	Drain Current	$T_C = 25\text{ }^\circ\text{C}, V_{GS} = 10\text{ V}$	-	-25	A
$I_{DM}^{*,**,***}$	Pulsed Drain Current	$T_C = 25\text{ }^\circ\text{C}, V_{GS} = 10\text{ V}$	-	-40	A
P_{tot}^*	Total Power Dissipation	$T_C = 25\text{ }^\circ\text{C}$	-	35	W
T_{stg}	Storage Temperature		- 55	150	$^\circ\text{C}$
T_J	Junction Temperature		-	150	$^\circ\text{C}$
I_S	Diode Forward Current	$T_C = 25\text{ }^\circ\text{C}$	-	-19	A
$R_{\theta JC}^*$	Thermal Resistance- Junction to Case		-	3.5	$^\circ\text{C} / \text{W}$
$R_{\theta JA}^*$	Thermal Resistance- Junction to Ambient		-	62.5	$^\circ\text{C} / \text{W}$

Notes:

- * Surface Mounted on 1 in² pad area, $t \leq 10\text{ sec}$
- ** Pulse width $\leq 10\text{ }\mu\text{s}$, duty cycle $\leq 1\%$
- *** Limited by bonding wire

4. Marking Information

Product Name	Marking
SN25P06G	<div style="display: inline-block; border: 1px solid black; padding: 2px;"> SN25P06G YWWXXX </div> YWW: Date Code

5. Ordering Code

Product Name	Package	Reel Size	Tape width	Quantity	Note
SN25P06G	DFN5*6			4000	

Note: NHCX defines "Green" as lead-free (RoHS compliant) and halogen free (Br or Cl does not exceed 900 ppm by weight in homogeneous material and total of Br and Cl does not exceed 1500 ppm by weight; Follow IEC 61249-2-21 and IPC / JEDEC J-STD-020C)

6. Electrical Characteristics (T_C = 25 °C Unless Otherwise Noted)

Symbol	Parameter	Conditions	Min	Typ	Max	Unit
Static Characteristics						
B _V DSS	Drain-Source Breakdown Voltage	V _{GS} = 0 V, I _{DS} = -250 μA	-60	-	-	V
V _{GS(th)}	Gate Threshold Voltage	V _{DS} = V _{GS} , I _{DS} = -250 μA	-1.0	-	-2.0	V
I _{DSS}	Drain Leakage Current	V _{DS} = -48 V, V _{GS} = 0 V	-	-	-1	μA
I _{GSS}	Gate Leakage Current	V _{GS} = ± 20 V, V _{DS} = 0 V	-	-	± 100	nA
R _{DS(on)} ^a	Channel On-State Resistance	V _{GS} = -10 V, I _D = -10 A	-	49	55	mΩ
		V _{GS} = -4.5 V, I _D = -5 A	-	59	65	
Diode Characteristics						
V _{SD} ^a	Diode Forward Voltage	I _{SD} = -10 A, V _{GS} = 0 V	-	-	-1.3	V
t _{rr}	Reverse Recovery Time	I _{SD} = -10 A, dI _{SD} / dt = 100 A / μs	-	25	-	Ns
Q _{rr}	Reverse Recovery Charge		-	7.5	-	nC
Dynamic Characteristics^b						
C _{iss}	Input Capacitance	V _{GS} = 0 V, V _{DS} = -30 V Frequency = 1 MHz	-	1408	-	pF
C _{oss}	Output Capacitance		-	64	-	
C _{rss}	Reverse Transfer Capacitance		-	47	-	
t _{d(on)}	Turn-on Delay Time	V _{DS} = -30 V, V _{GEN} = -10 V, R _G = 4.5 Ω, R _L = 3 Ω, I _{DS} = -10 A	-	14	-	nS
t _r	Turn-on Rise Time		-	51	-	
t _{d(off)}	Turn-off Delay Time		-	197	-	
t _f	Turn-off Fall Time		-	112	-	
Gate Charge Characteristics^b						
Q _g	Total Gate Charge	V _{GS} = -10 V, V _{DS} = -30 V, I _{DS} = -10 A	-	23	-	nC
Q _{gs}	Gate-Source Charge		-	6.5	-	
Q _{gd}	Gate-Drain Charge		-	3	-	

Notes:

- a : Pulse test ; pulse width ≤ 300 μs, duty cycle ≤ 2 %
- b : Guaranteed by design, not subject to production testing

7. Typical Characteristics

Power Dissipation

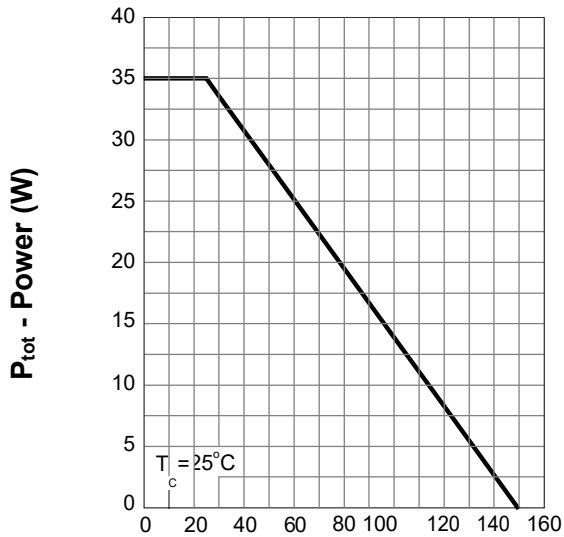

T_j - Junction Temperature ($^\circ\text{C}$)

Drain Current

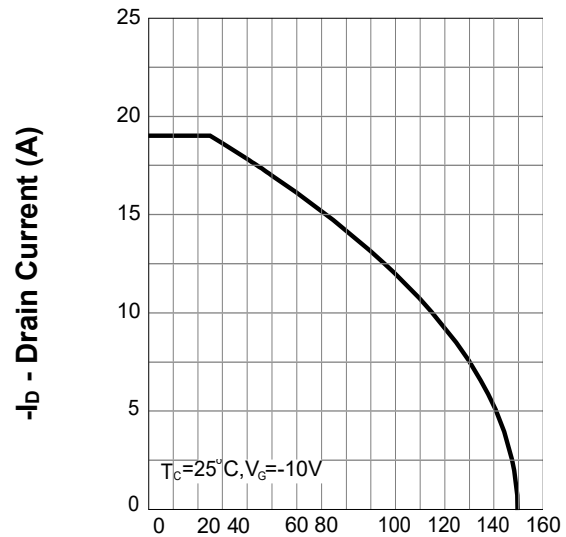

T_j - Junction Temperature ($^\circ\text{C}$)

Safe Operation Area

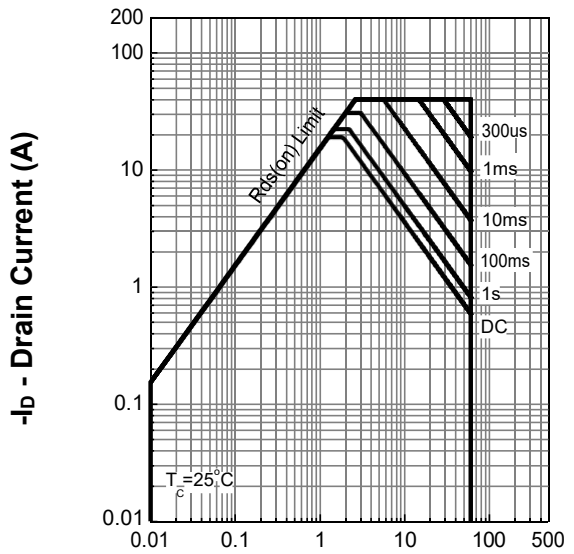

$-V_{DS}$ - Drain-Source Voltage (V)

Thermal Transient Impedance

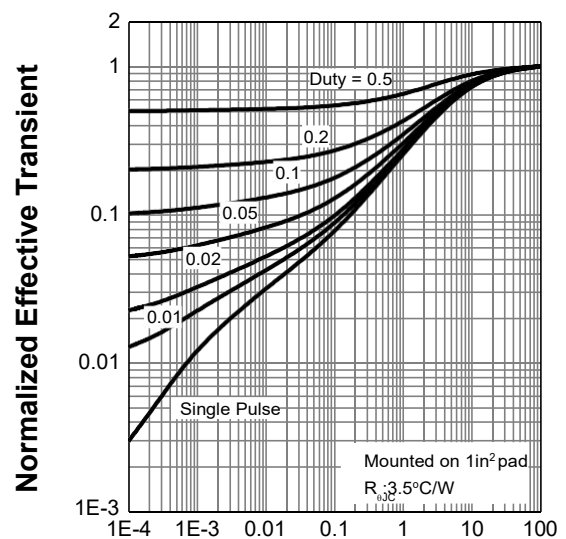

Square Wave Pulse Duration (sec)

7. Typical Characteristics (cont.)

Output Characteristics

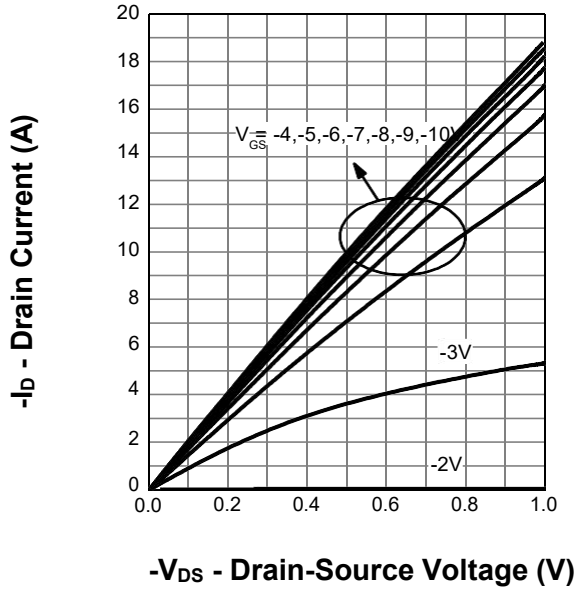

Drain-Source On Resistance

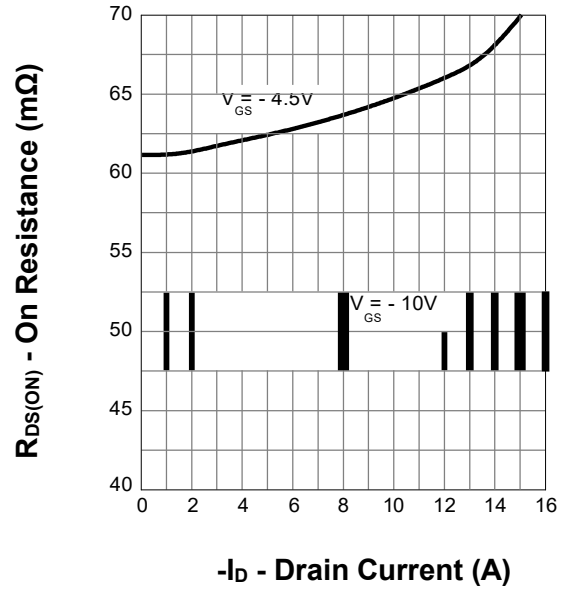

Transfer Characteristics

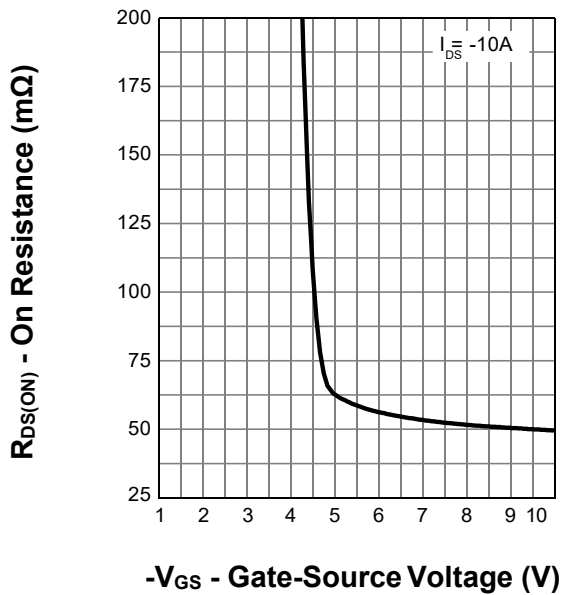

Gate Threshold Voltage

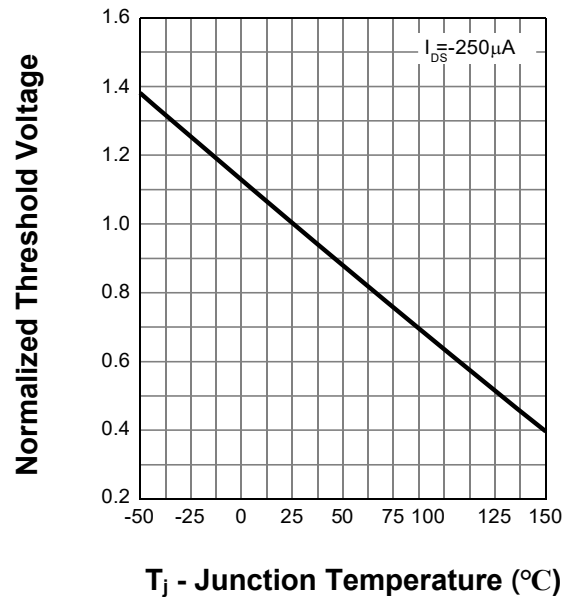

7. Typical Characteristics (cont.)

Drain-Source On Resistance

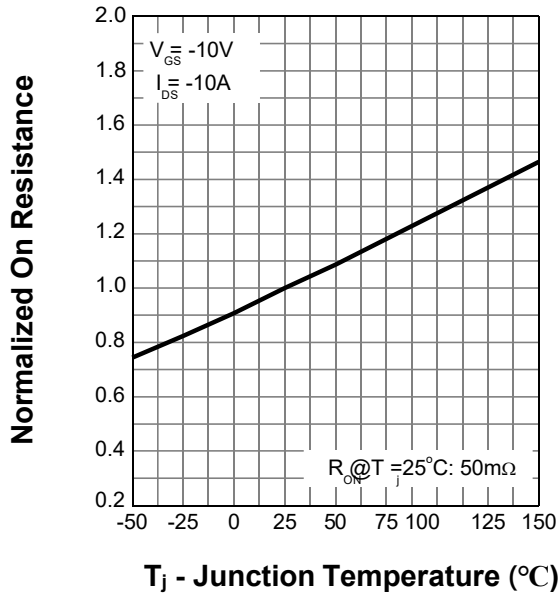

Source-Drain Diode Forward

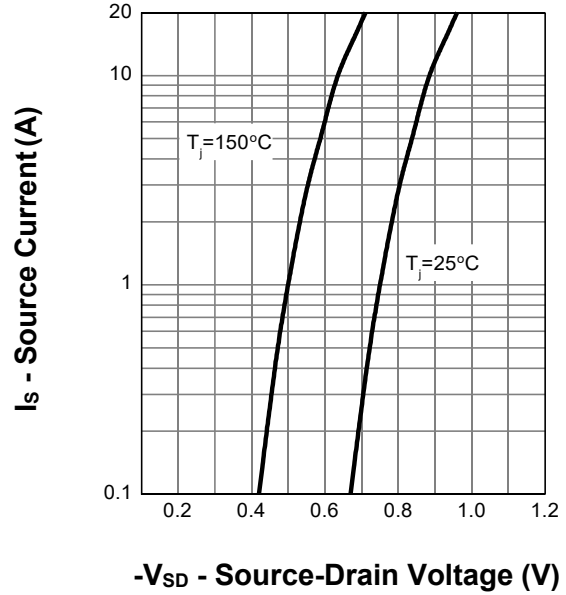

Capacitance

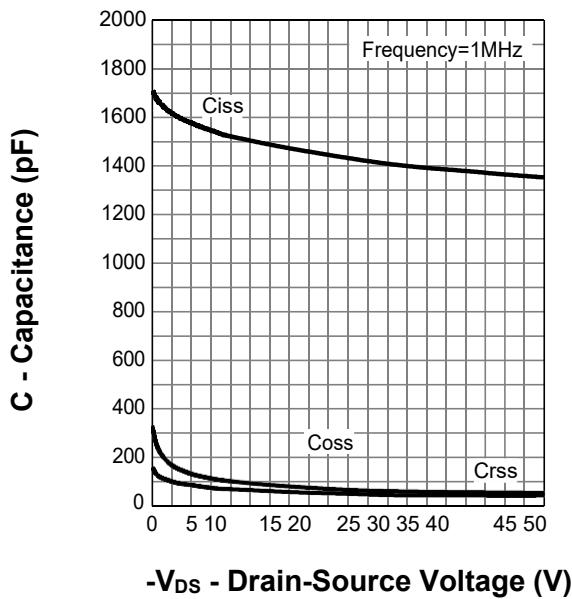

Gate Charge

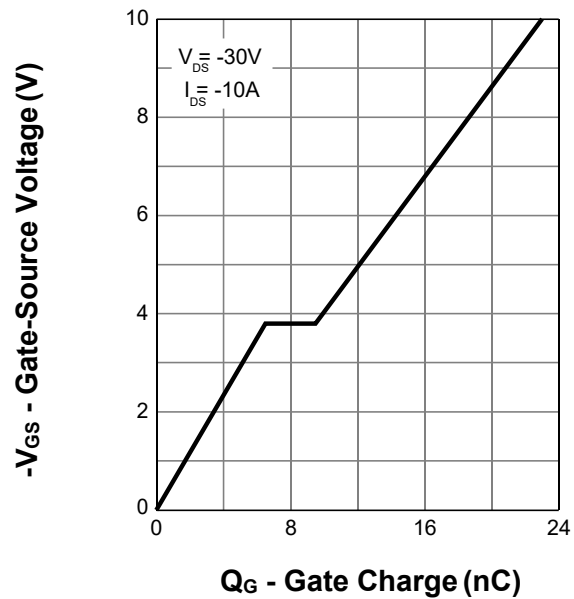

8.Package Dimensions

PDFN5x6 - 8L Package

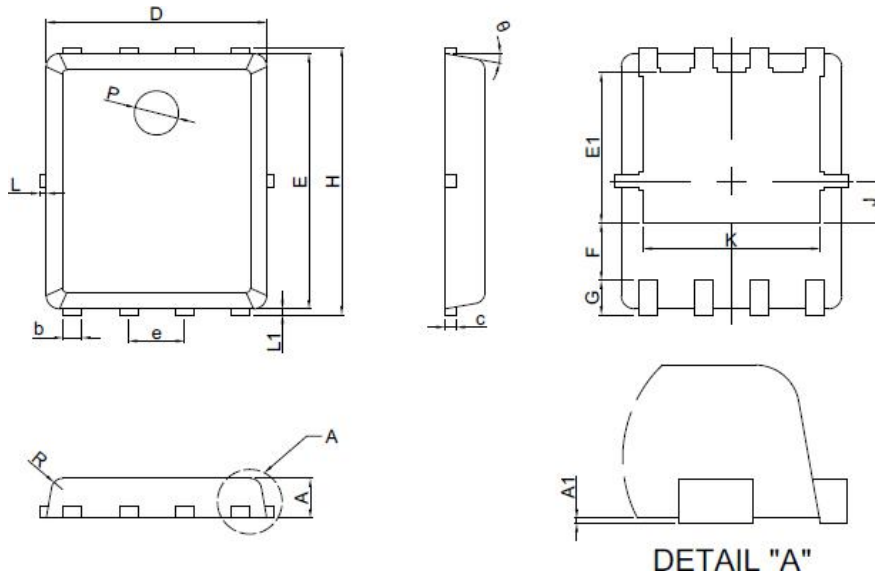

Symbol	Dimensions In Millimeters	
	MIN.	MAX.
A	0.80	1.00
A1	0.00	0.05
b	0.35	0.49
c	0.254REF	
D	4.90	5.10
F	1.40REF	
E	5.70	5.90
e	1.27BSC	
H	5.95	6.20
L1	0.10	0.18
G	0.60REF	
K	4.00REF	
L	-	0.15
J	0.95BSC	
P	1.00REF	
E1	3.40REF	
θ	6°	14°
R	0.25REF	